

Design of a Two-Dimensional Proportional Solenoid for Miniature Directional Control Pneumatic Valves

Yeh-Sun Hong*, Dong-Hyun Ha, Myung-Ki Yeom

*School of Aeronautical & Mechanical Engineering, Hankuk Aviation University,
Hwajon-dong, Duckyang-ku, Koyang-city, Kyungki-do 412-791, Korea*

In this paper, a new proportional solenoid invented for pneumatic directional control valves is introduced. The new proportional solenoid has two-dimensional structure and a pivoting armature on which the friction force is inherently negligible. Another advantageous feature of this solenoid is that its mechanical parts can be easily manufactured and assembled. The working principle and design example of the new proportional solenoid, its application to the activation of a 4/3-way directional control valve, and the evaluation of its control performance in a position control loop are reported.

Key Words : Two-Dimensional Proportional Solenoid, Double Flapper-Nozzle Valve, 4/3-Way Directional Control

Nomenclature

F	: Magnetic force (N)
H	: Height of solenoid (mm)
I	: Input current to solenoid (A)
K_p	: Proportional control gain
m	: Inertia mass of piston (kg)
NI	: Magnetomotive force (A-turns)
Q_L	: Load flow (NI/min)
r	: Reference input (mm)
s	: Armature displacement (mm)
θ	: Armature angle ($^\circ$)
T_1, T_2	: Time constants (sec)
μ_0	: Permeability of air (H/m)
y	: Piston position (mm)

1. Introduction

For the closed loop control of pneumatic actuators with small volumetric displacement, miniature 4/3-way directional control proportional valves having max. flow rate of less than 15 l/min

are frequently required. If they are to be directly installed on the actuators, they must be small in size. And the price should be also acceptable to promote their commercial application such as position or force control of robotic fingers (Czinki and Hong, 1997; Ryu and Hong, 1998; Hwang and Hong, 1998).

As an electromechanical signal converter for servo-pneumatic valves, there have been proportional solenoids, electric motors, torque motors, and piezoelectric actuators (Murrenhoff, 2002). Among them, the proportional solenoids are distinguished by the easiness to control, robustness, and low price.

The conventional proportional solenoids have axis-symmetrical structure with a sliding armature. Unfortunately, it is difficult to maximize their power-to-volume ratio, when they are miniaturized, because the reduction of the friction force on the sliding armature needs relatively large space for additional motion guides such as linear bearings.

In this paper, a new proportional solenoid invented for miniature pneumatic control valves is introduced. Ryu and Hong (1998) reported the application of a double flapper valve as miniature 4/3-way directional control valve, using an on-

* Corresponding Author.

E-mail : yshong@hau.ac.kr

TEL : +82-2-300-0287; **FAX :** +82-2-3158-2191

School of Aeronautical & Mechanical Engineering, Hankuk Aviation University, Hwajon-dong, Duckyang-ku, Koyang-city, Kyungki-do 412-791, Korea. (Manuscript Received August 14, 2002; Revised April 18, 2003)

off type dc-solenoid to activate proportionally to input current. The basic structure of the new proportional solenoid is similar to that of the on-off type, except its specially shaped armature and pole. The magnetic force of the on-off solenoid is heavily dependent on the armature displacement. Therefore, if it is loaded by a return spring, the stable conversion of magnetic force into armature displacement is possible only in a limited range of the armature movement where the magnetic force changes small. This makes it difficult to combine the solenoid with the valve body so that low linearity error is obtained.

But the magnetic force of the proportional solenoid is proportional to the input current and changes slightly within the whole working range of the armature displacement. Therefore, the linearity error between the input current and the armature displacement is less sensitive to the spring load curve and smaller than that of the on-off solenoid (Hong, 1986).

Besides, the new proportional solenoid takes over the advantageous features of the on-off type for miniaturization. It has two-dimensional structure and a pivoting armature instead of sliding one. The friction force on the armature is inherently negligible. Its mechanical parts can be manufactured by pressing thin plates and easily assembled.

In order to test the practicability of the proportional solenoid, it was applied to the activation of a double flapper nozzle valve, and a pneumatic cylinder was position-controlled with this valve. In the following, the working principle and design example of the new proportional solenoid, its improved linearity, and the applicability as control element are reported.

2. Working Principle of a New Proportional Solenoid and its Design Process

Figure 1 depicts the new 2-dimensional proportional solenoid. It consists of a pole core with specially shaped pole face, a pivoting armature with extended push arm having a roller on its tip, and a coil wound around the pole core. The

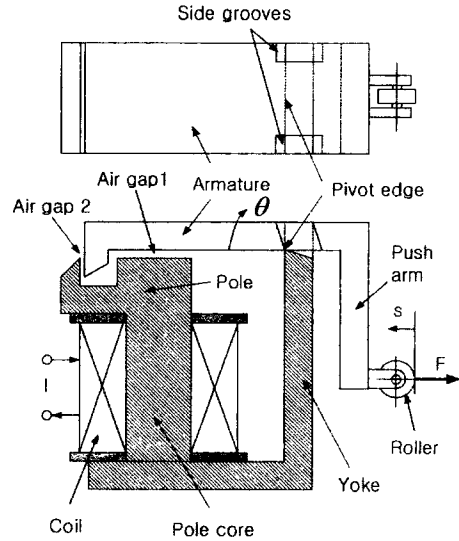

Fig. 1 Schematics of a new proportional solenoid

armature is supported on the pivot edge without any remarkable friction, while its rotational motion is guided by side grooves. The roller makes contact with a valve control element which is not shown in the figure.

Since the magnetic structure is two-dimensional, the max. magnetic force can be increased simply by enlarging the height.

Similarly to the conventional axis-symmetrical proportional solenoids, the relationship between the electromagnetic force pulling the armature and its rotation angle, θ is influenced by the pole shape. It is the air gap 2 that distinguishes the proportional solenoid from the on-off types. The on-off solenoids have only one air gap oriented to the y-direction: i.e. air gap 1.

The flux density vector in the air gap 1 will be almost parallel to the y-axis, when the armature angle is not large. Therefore, the magnetic force induced there will have the dominant component in the y-direction. As the armature rotates in the clockwise direction, this component, F_{1y} decreases inversely proportional to the square of rotation angle (Roters, 1964).

In contrast with that, the magnetic force induced in the air gap 2 will have larger component in the x-direction (F_{2x}) than in the y-direction (F_{2y}), when the armature angle is small, because

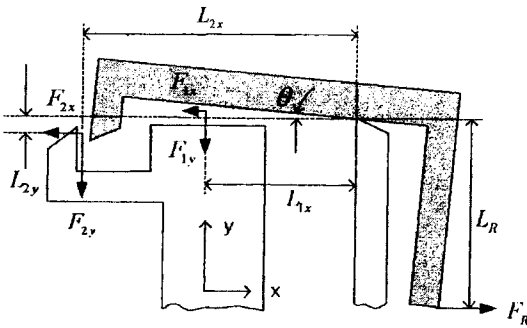
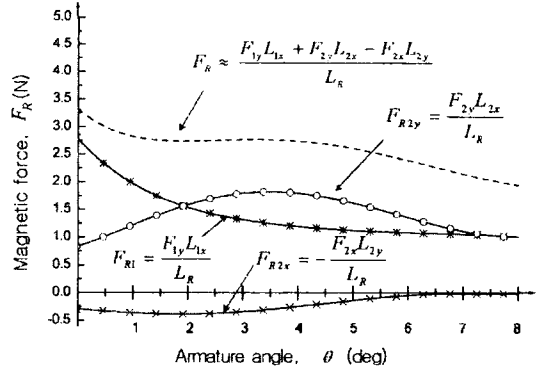

Fig. 2 Magnetic forces acting on the armature and their change with armature angle



the flux density vector there will be almost perpendicular to the y -axis. As the armature rotates, however, F_{2y} will increase, while F_{2x} decreases, because the angle between the flux density vector and the y -axis becomes sharper (see the magnetic flux lines shown in Fig. 4(b)).

These force components will develop pulling forces $F_{R1y} = \frac{F_{1y}L_{1x}}{L_R}$, $F_{R2x} = -\frac{F_{2x}L_{2y}}{L_R}$, and $F_{R2y} = \frac{F_{2y}L_{2x}}{L_R}$ at the push arm's tip, respectively, since the armature is freely supported by the pivot edge. If they are summed together, the total force, F_R is equal to $\frac{F_{1y}L_{1x} + F_{2y}L_{2x} - F_{2x}L_{2y}}{L_R}$, as illustrated in Fig. 2 constructed by FEM-based analysis.

It is to be noted that the resultant force, F_R can be made increasing, decreasing or constant in response to the change of armature angle within a specific range by proper tailoring of $F_{2x}L_{2y}$ and $F_{2y}L_{2x}$ for given $F_{1y}L_{1x}$. Fig. 3 shows the design parameters deduced from the working principle, considering that the force components F_{2x} , F_{2y} , and F_{1y} are mainly influenced by L_{23} , θ_2 , θ_1 , g_2 , L_{12} , and g_1 .

The design goal of this study is to make the force pushing the roller against a valve control element constant, i.e. independent of the armature angle. As a general approach to understand the influence of the design parameters on the magnetic force at certain armature angle, the solenoid can be mathematically modeled by the so-called reluctance method. But, in this case, the design

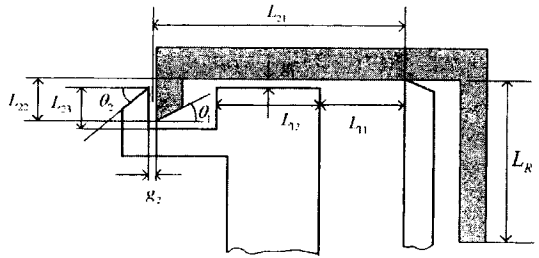

Fig. 3 Design parameters for proportional solenoid

parameters cannot be analytically determined from the magnetic equivalent circuit eq.s, because the iron parts undergo magnetic saturation. That is, the eq.s can be solved only by a numerical iterative process, the nonlinear magnetization curve of the iron parts being looked up. Besides, the local saturation of the pole cannot be fully taken into account by the reluctance method (Roters, 1964 ; Song, 1980 ; Hong, 1986). Therefore, the design process is generally based on the cut and try method. That is, with L_{11} , L_{12} , g_1 , and L_{22} roughly assumed, finding the values of g_2 , L_{21} , L_{23} , θ_1 , and θ_2 should be repeated, until the design goals are met. If it is not successful, the assumed values should be modified. Basically, $F_{1y}L_{1x}$ is related with L_{11} , L_{12} , and g_1 , whereas $F_{2x}L_{2y}$ and $F_{2y}L_{2x}$ are determined by L_{21} , L_{22} , L_{23} , and g_2 . θ_1 and θ_2 have an effect on the magnetic saturation of iron parts bordering the air gap 2.

In this study, a commercial FEM-based analysis program (ANSOFT) was used to simulate the cause and effect of the design parameters, because it gives more accurate and various in-

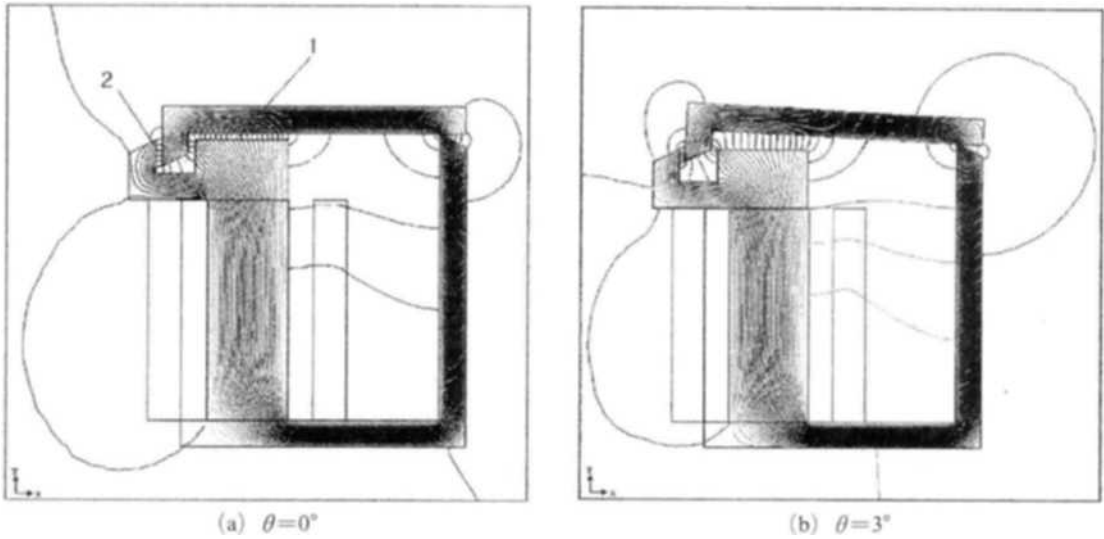

Fig. 4 Numerically computed magnetic flux lines ($NI=500$ A-turns)

formation than the reluctance method.

Figure 4 shows computed flux lines of the solenoid as example. It is to be noted that among the flux paths in the air gap, the paths 1 and 2 have apparently dominant influence on the magnetic force induction, while the other paths represent fringing phenomenon.

Figure 5 shows a prototype of the proportional solenoid designed to experimentally verify its working principle. Its basic geometry was imported from the on-off solenoid used in (Ryu, and Hong, 1998), because it was developed to replace the on-off type.

If we modify only the shape of the armature and the pole with the basic magnetic structure fixed, the force-to-armature displacement curve will change, but the energy stored in the electromagnetic field, which is to be converted into mechanical work, remains constant. The mechanical work that the on-off solenoid in (Ryu, and Hong, 1998) could perform within the displacement range from 0 to 1 mm, was approximately 3 Nmm at the magnetomotive force of 400 A-turns. Assuming the same displacement range, the constant force of the proportional solenoid should be in the level of 3 N. With the increased electromotive force of 500 A-turns, the proportional solenoid was expected to generate the force greater than 3.5 N.

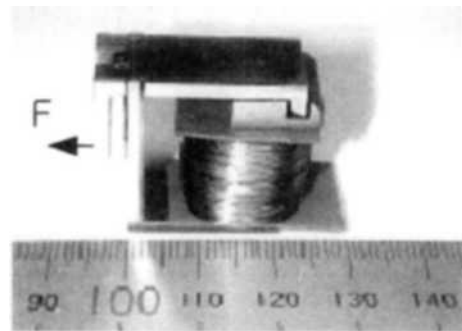
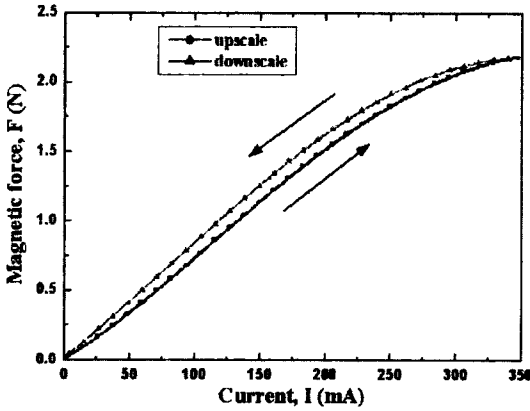

Fig. 5 Prototype of a proportional solenoid ($L_{21}=21$, $L_{22}=2$, $L_{11}=11.5$, $L_{12}=7$, $L_R=13$, $H=12$ (mm))

Apart from it, the working range of the armature displacement should be greater than 0.4 mm, because the max. flapper displacement was designed to be ± 0.125 mm (total 0.25 mm), and the min. tolerance greater than 0.1 mm was required for matching the neutral positions of the solenoid and the flapper.

The magnetic force-to-armature displacement curves and force-to-current curve of the prototype was measured and displayed in Fig 6, where 200 Hz dither signal was applied. They indicate the hysteresis of $\pm 2.5\%$, linearity error of less than $\pm 10\%$, and max. force of greater than 3 N. The magnetic force was lower than the expected



(a) Magnetic force-to-current curve

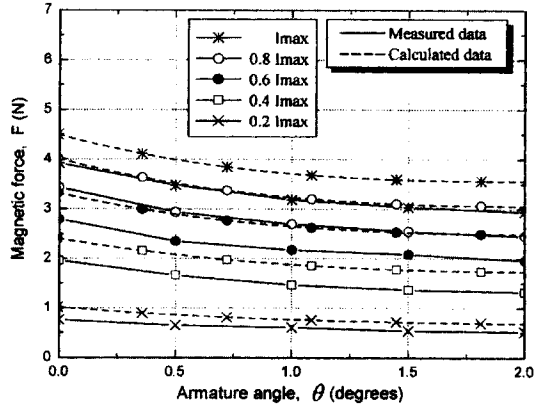

(b) Force-to-armature displacement curves

Fig. 6 Static performance of the proportional solenoid ($I_{max}=0.4$ A)

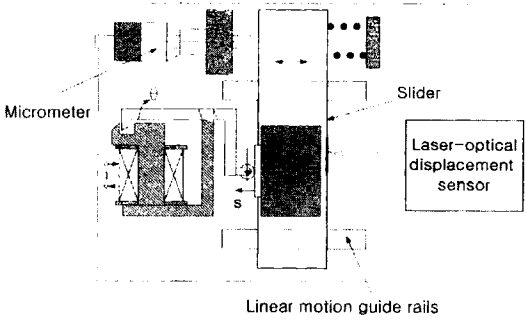

Fig. 7 Experimental setup for the force measurement

value, but still sufficient for the activation of the valve control element described in the next section.

The computed data in Fig. 6(b) correspond to the results of the numerical analysis. Although they were higher than the measured data, the influence of the pole shape on the relationship between the magnetic force and the armature angle could be well predicted by them.

The experimental setup for the static performance measurement is schematically illustrated in Fig. 7. While the armature was manually moved by a micrometer, its displacement and force were measured by a laser-optical sensor and a load cell, respectively, at the tip of the push arm. The rotation angle of the armature, θ is related with the displacement of the push arm, s by $s=L_R\theta$. When the armature rotates from 0 to 2° , the push arm moves from 0 to 0.4 mm.

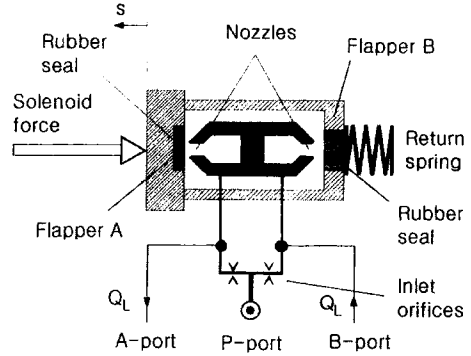

Fig. 8 Schematics of a double flapper nozzle valve for 4/3-way directional control

3. Configuration of a 4/3-way Directional Valve

In this study, the proportional solenoid was applied to the activation of a 4/3-way directional valve in order to test its capability. Fig. 8 depicts the schematics of the valve based on the double flapper nozzle mechanism introduced in (Ryu and Hong, 1998). Although the flapper nozzle valves are disadvantageous in concern with the significant null leakage flow, they have simple structure and good linearity between the flapper displacement and the control pressure.

Table 1 shows the design specification of the double flapper nozzle valve whose mathematical model is described in a lot of literatures (Merriit, 1967; Blackburn et al., 1960).

The blocked load port pressures-to-flapper displacement curves and the no load flow rate-to-flapper displacement curve of the designed valve were measured as shown in Fig. 9, where the flapper was moved manually. The curve in Fig. 9(b) shows the linearity error of $\pm 6\%$ within the $\pm 60\%$ range of max. flapper displacement.

Table 1 Design specification of a double flapper nozzle valve

Inlet orifice diameter	0.4 mm
Nozzle diameter	0.7 mm
Max. flapper displacement	± 0.125 mm
Max. no load flow rate (supply pressure=6 bar)	7 Nl/min
Stiffness of return spring	2.1 N/mm

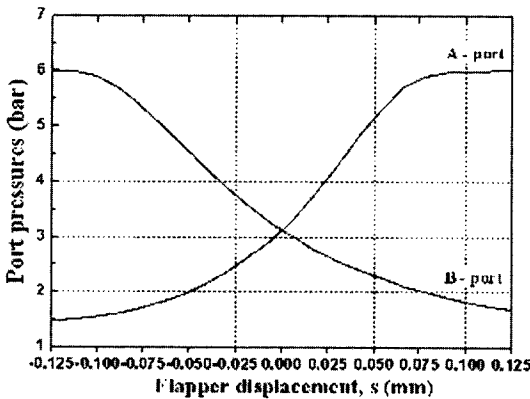

(a) Blocked load port pressures-to-flapper displacement curves

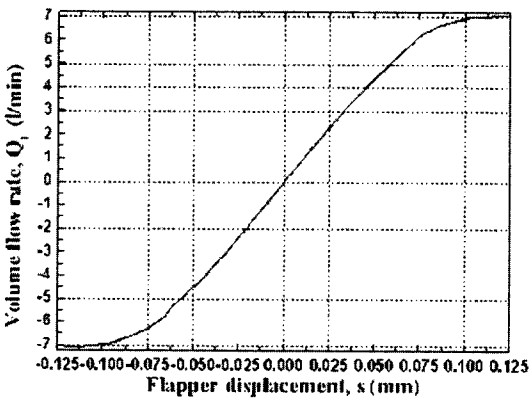

(b) No load flow rate-to-flapper displacement curve

Fig. 9 Flow characteristics of a double flapper nozzle valve

We can refer to these curves, when we evaluate of the influence of the proportional solenoid on the static performance of the valve.

4. Performance of a New 4/3-way Proportional Directional Control Valve

Figure 10 illustrates the 4/3-way proportional directional control valve activated by the new proportional solenoid. A plate spring was used to support the lefthand flapper. The static characteristics of the valve were measured under the blocked-load condition and displayed in Fig. 11. The input signal corresponds to the voltage input to a servo-amplifier. The curves differ very slightly from them in Fig 9, except the hysteresis loop caused by the friction on the flapper mechanism. It is also to be noted that the influence of the flow force is negligible.

When a stepwise command signal was applied to the valve under the same blocked load condition, it could respond with a rising time of 23.7 ms, as shown in Fig. 12, where the port pressures were measured as controlled variable. The dynamic response was mainly dependent on the inductance and resistance of the solenoid coil.

In order to confirm the practicability of the new valve, it was further applied to the position control of a commercial pneumatic cylinder with

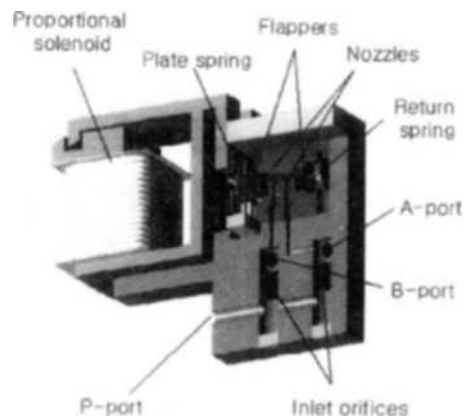
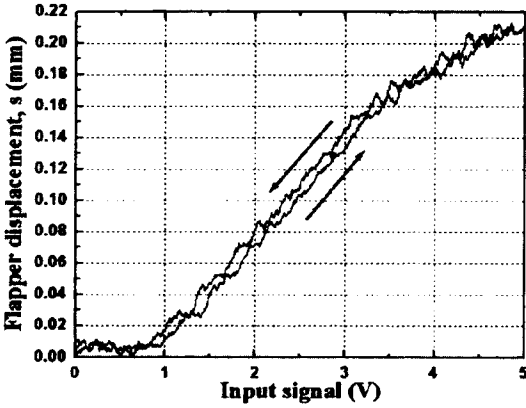
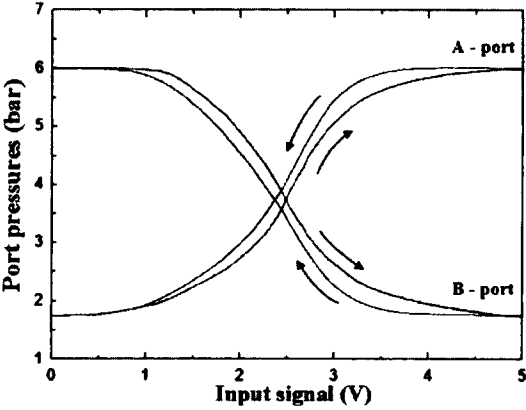

Fig. 10 4/3-way proportional directional control valve (W=45 mm, L=39 mm & H=12 mm)

the piston diameter of 16 mm and the stroke of 80 mm. Fig. 13 illustrates the experimental setup.



(a) Flapper displacement-to-input signal curve



(b) Port pressures-to-input signal curves

Fig. 11 Static characteristics of the valve (supply pressure=6 bar)

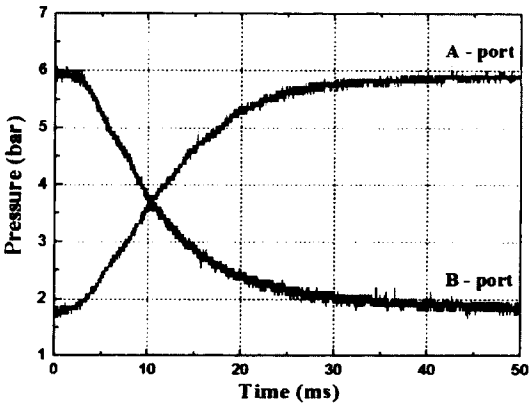

Fig. 12 Step input response of the control port pressures

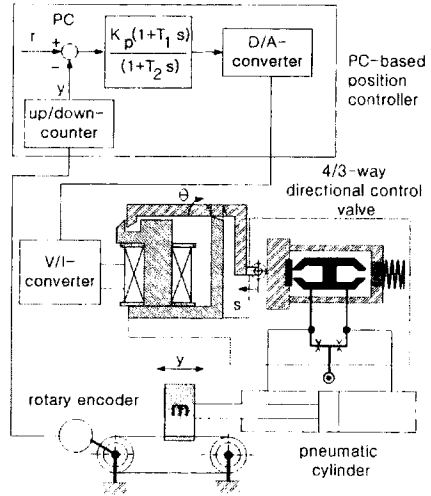
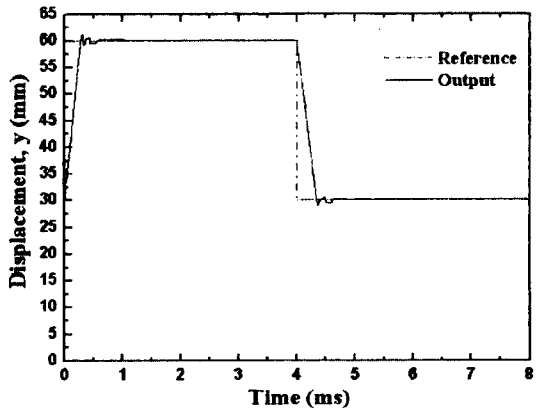
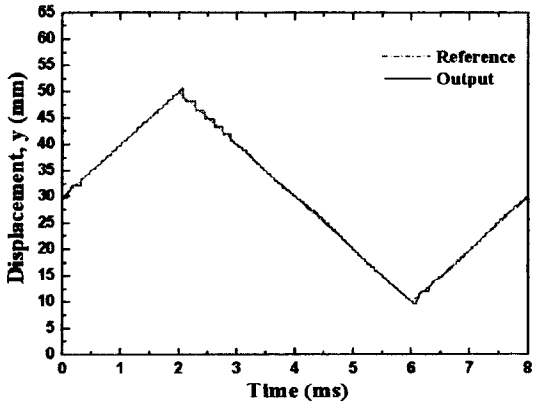

Fig. 13 Experimental setup of position control system



(a) Step-input response



(b) Ramp-input response

Fig. 14 Dynamic response of a position-controlled pneumatic cylinder

For this experiment, a P-controller combined with lead compensator and an incremental position sensor were used. As the best achievable performance, the piston could respond to a stepwise command signal with a rising time of 0.26 s and a steady state error of less than 0.1 mm, as Fig. 14 (a) indicates. When a ramp signal was applied, max. control error of 0.15 mm could be registered (see Fig. 14(b)). The results were good enough to verify the usefulness of the new valve mechanism (Czinki and Hong, 1997; Ryu and Hong, 1998), considering that the hysteresis error of the valve had significant influence on the control error.

There remain certainly several works to improve the control performance. But the scope of the study was mainly concerned with the development of the new proportional solenoid.

5. Review

The new proportional solenoid presented so far was made of common low carbon steel and its design should be further refined in respect to the electromagnetic efficacy.

However, its performances such as linearity error and hysteresis turned out to be on a comparable level with those of the conventional proportional solenoids. And they could be improved by applying ferromagnetic materials with higher saturation limit and lower magnetization hysteresis.

On the other hand, finding the best shape of the pole face for given design goal will need further study on the derivation of relationships between design parameters and their effect on the force-to-displacement curves.

It is noteworthy that the new proportional

solenoid has structural advantages to the widely-used conventional axis-symmetrical type in respect to the simplicity of mechanical structure and its miniaturization.

References

- Blackburn, J. F., Reethof, G. and Shearer, J. L., 1960, *Fluid Power Control*, New York, Technology Press of M. I. T. and Wiley
- Czinki, A. and Hong, Y. -S. 1997, "Design and Control of an Anthropomorphic Servopneumatic Finger Joint," *Oelhydraulik and Pneumatik*, March, 1997, pp. 181~184.
- Hong, Y. S., 1986, "Berechnung, Verbesserung und Neuentwicklung von Proportionalen Magneten," *Dr.-Ing. Dissertation*, RWTH Aachen.
- Hwang, T. J. and Hong, Y. S. 1998, "Design and Experiment of a Flapper-Nozzle Type 3/2-way Proportional Valve for Position Control of a Miniature Pneumatic Rotator," *J. Korean Society of Mechanical Engineers*, Vol. 22, No. 9, pp. 1741~1747.
- Merrit, H. E., 1967, *Hydraulic Control Systems*, John Wiley & Sons Inc.
- Murrenhoff, H., 2002, "Trends in valve development," *3rd Int. Fluid Power Conference*, Aachen, Germany, pp. 109~143.
- Roters, H. E., 1964, *Electromagnetic Devices*, New York, John Wiley & Sons Inc.
- Ryu, S. B. and Hong, Y. S., 1998, "Design and Experiment of a Miniature 4/3-way Proportional Valve for a Servo-Pneumatic Robot Hand," *J. Korean Society of Precision Engineering*, Vol. 15, No. 12, pp. 142~147.
- Song, C. S., 1980, "Study of an Electro-Hydraulic Proportional Compound Valve," Ph. D. Thesis, KAIST.